

Agilent N5970A Interactive Functional Software

Battery Current Drain Solution

Application Note

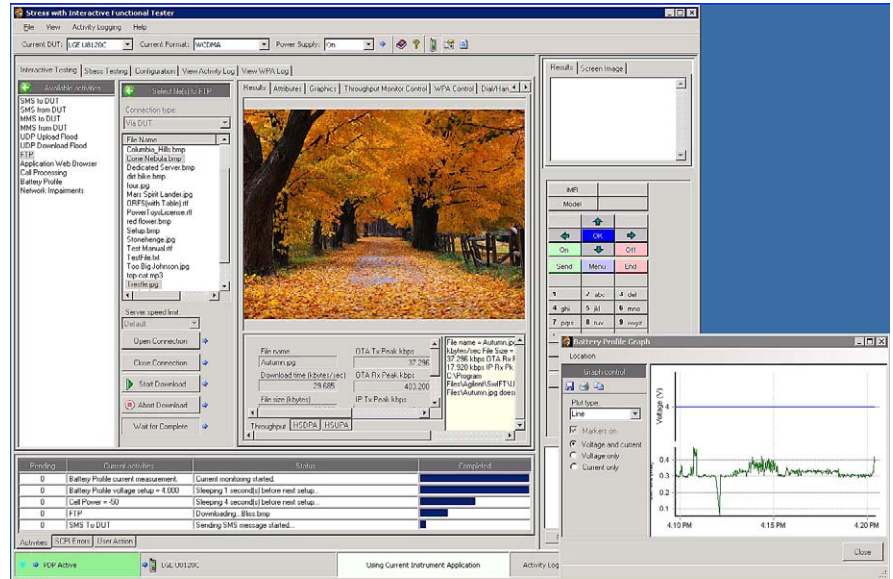

**Improve battery performance
for your cellular device by
finding issues earlier!**

Due to the ever-increasing complexity of cellular wireless devices, there is a crucial need to test these devices to understand how a battery will operate under real-world conditions. Capturing and analyzing battery performance issues early in the device's design stages reduces the more costly and time-consuming rework required to fix problems that are found downstream such as during interoperability testing or even in a customer's hands. This application note focuses on the new N5970A Interactive Functional Test (IFT) solution, which is Agilent's battery current drain solution for cellular device design engineers that can be used to analyze the battery current drain while testing your device under real-world scenarios.

IFT Overview

The N5970A Interactive Functional Test (IFT) software is designed to be used in conjunction with the 8960 for its base station emulation capabilities as well as the Agilent 66319/21 B or D Mobile Communications DC Source which is ideally suited to power cellular devices. Together, these components create the IFT solution for battery current drain analysis of cellular devices. Using this solution will help ensure your design provides optimal battery performance while still meeting important time to market goals.



Methods of Battery Current Drain Test

Traditional methods of specifying the expected life of a battery simply consisted of estimating hours of talk time and hours in standby mode. Today, since data is so important to most users (except the “Nominal Use” users), more tests must be run to ensure the device can handle all the applications and services to which a user has access.

New methods of testing a battery’s current drain performance based on more than just talk time and standby time is sometimes referred to as Days of Use test. A typical Days of Use test includes testing the current drain of the device’s battery while performing key user activities but also adds other factors contributing to current drain that are not traditionally taken into account, such as button presses and back light activation.

The Agilent 8960/IFT battery current drain solution not only enables you to test with methods such as Days of Use testing, but takes this concept even further in several ways as described in the next section.

Key Benefits of the IFT Solution

Meeting time to market goals and also having time to improve a device’s design requires efficient use of the design engineer’s time. The IFT solution allows design engineers to spend more time designing and less time troubleshooting in several ways.

No Manual User Interaction

Typical Days of Use testing requires a person to manually press buttons and perform key activities as they would on a real network.

Test System Automation

The 8960/IFT solution provides an automated means of testing the battery current drain on a device by controlling the 8960 lab application’s powerful data channel capabilities and a power supply. This automation is not only a much easier way to test battery current drain, but it also brings real-world test scenarios into the lab.

Intuitive User Interface

First, IFT provides an intuitive interface for controlling which activities to run and when to run them. This includes overlapping activities so that they are run at the same allowing you can emulate realistic end-user scenarios.

Simultaneous Activities

Further, this solution is the only solution that allows automation of running multiple activities at the same time (such as receiving an SMS while downloading a file, etc). This ability to overlap activities is crucial to providing confidence that the test results are reliable and a true representation of what to expect when the device is operated in a real network.

Troubleshooting Tools

Another way that this solution makes more efficient use of design engineers’ time is by providing additional troubleshooting tools, such as activity logging and protocol logging, to help quickly isolate problem areas.

Current Drain Analysis

A further advantage of using the 8960/IFT solution to better test current drain performance is that, depending on your needs, you can use the generic battery current drain view or you can use the 14565B Current Drain Analysis software, which is the most flexible and advanced battery profile analysis software on the market today.

Test more in less time, earlier

Finally, since this type of testing is done earlier in the development lifecycle of the device, important issues will be resolved faster and earlier – saving time and money.

User Profiles

Each individual uses his/her cellular device differently; however users generally fall under the following three main profiles.

Gaming users – These users constantly stress their mobile devices with full upload and download throughput rates as well as continuously stress the device’s video capability. Users who are involved in high-stakes gaming, such as gambling remotely with Las Vegas casinos, rely very heavily on the reliability of their device.

Business savvy/teenage users – These users also constantly stress their devices by sending emails, making voice calls and running other data applications such as browsing the web and/or sending or receiving a file via FTP.

Nominal use users – These users typically do not fully utilize all the capabilities of their mobile devices. They use fewer data applications than those users that fall under the business savvy user profile. However, their device still must be able to perform rudimentary operations including moving through cells, performing handovers, and operating in different fading environments.

Stages of Battery Performance Testing

Each of the above profiles contributes to the increased complexity of cellular devices. One commonality between each of the three main user profiles is that they want to know how long they can expect their battery to last. The widely varying usage of devices pose big challenges to device design engineers and testing battery performance must occur in several test stages of the device development lifecycle including: integration, validation, and acceptance testing.

- Integration engineers evaluate how new hardware, applications, and services affect the battery life of the device and find issues that normally are found downstream.
- Validation engineers run more rigorous tests to ensure as many issues as possible are caught before the device is released to reduce the number of expensive validation cycles.
- Acceptance tests, which are run in the field, are the final test requirements the device must meet before the device is deemed acceptable to operate on a particular network.

Battery Current Drain Analysis Solution Requirements

The following are required battery current drain analysis components as shown in Figure 1:

- 8960 wireless communications test set with an installed lab application to emulate a base station and setup mobile device test conditions
- PC running N5970A Interactive Functional Test software which controls the 8960 and 14565B software (if used), which can also be used to remotely control the device under test (DUT)
- PC to host server applications required by many of the IFT activities.

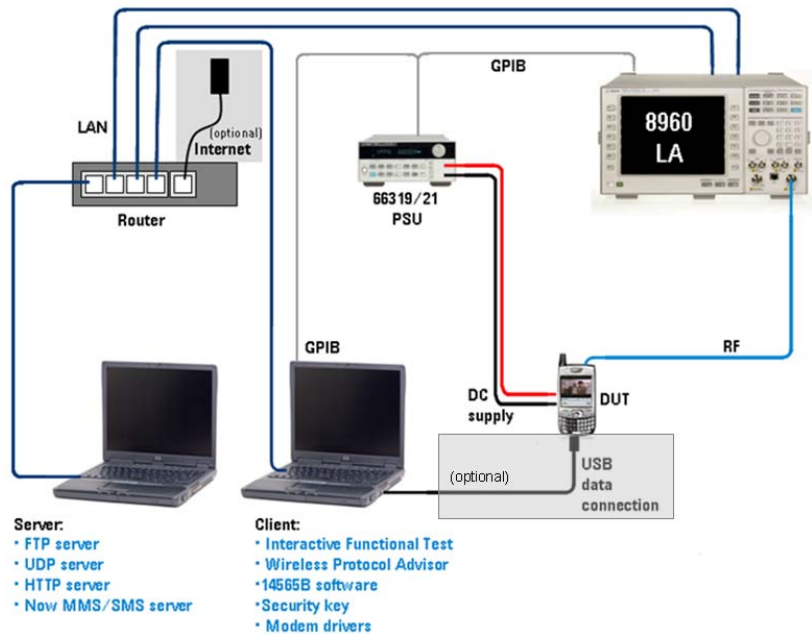

Figure 1: IFT solution diagram

- 66319/21 B or D mobile communications DC source with high speed digitizer to measure battery current drain and power the DUT.
 - Single channel fast response to emulate battery
 - Alternate zero-burden logging ammeter and voltmeter operation, battery run-down test

Unlike the 66319/21 B or D, general purpose power supplies do not have the ability to provide fast response time to meet the demands of mobile device current drain or the ability to compensate for the battery's internal resistance for accurate current drain results.

- A DUT (appropriate modem cable and drivers are necessary if testing the device as a modem)

Optional Battery Current Drain Software

14565B software is a more advanced battery current drain interface that is controlled via the interactive functional test software, which in turn is controlling the 66319D. This software is not required for the 8960/IFT solution, but is recommended for users who need...

- A tailored solution for mobile wireless device battery drain
- Data logging, and Complementary Cumulative Distribution Function (CCDF) capture
- Amp-hr and watt-hr computation, save, recall and compare, CCDF analysis, zoom and markers
- Real-time data compression
- Long term battery drain analysis
- To do software regression testing

Generic Battery Current Drain Analysis

An example of the generic battery current drain analysis view within IFT is shown in Figure 2. This view provides a real-time view of the voltage settings and current readings from the power supply. In this example, the device was turned-on and supplied a constant or fluctuating voltage. Once the device camped to the 8960, a modem connection was established and files were downloaded via the modem connection using FTP. Additional activities can be layered on top of existing activities while this current drain analysis is running so you can see the impact on a device's battery when different activities are occurring at the same time but changing at different rates.

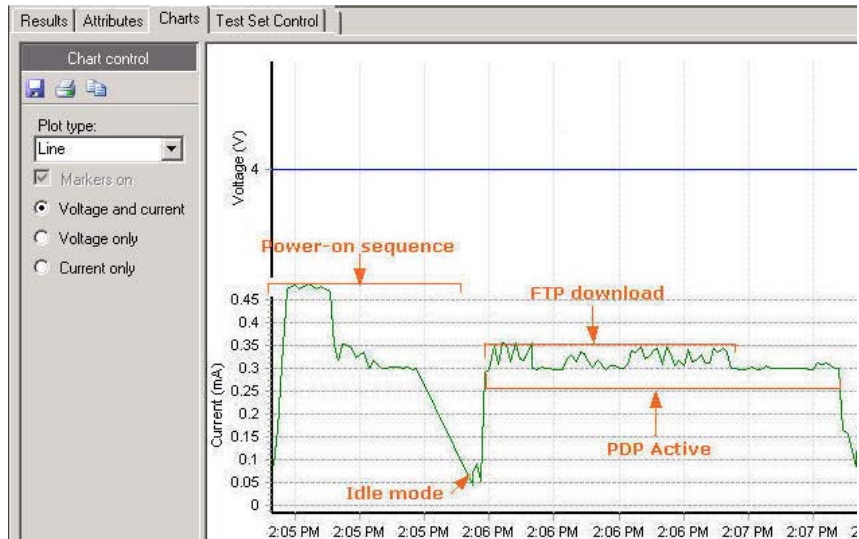

Figure 2: IFT generic battery current drain analysis view

Advanced Battery Current Drain Analysis

For more advanced battery current drain analysis than is provided with the generic battery current drain solution, the IFT software utilizes the Agilent 14565B Device Characterization software. IFT controls the 14565B software and puts it into a special automation mode.

The more advanced features provided include allowing you to choose between capturing a data log or a CCDF response and allowing you to indicate which events (such as the start or stop of an activity) should be tagged. Using this software, you can accurately log battery current drain for up to 1000 hours.

The example data logging profile in Figure 3 shows a data log of an FTP download activity with event tags marking the start and end of each file. (The pink, blue, and cyan colors on the graph represent maximum, average and minimum values, respectively, from each integration interval.)

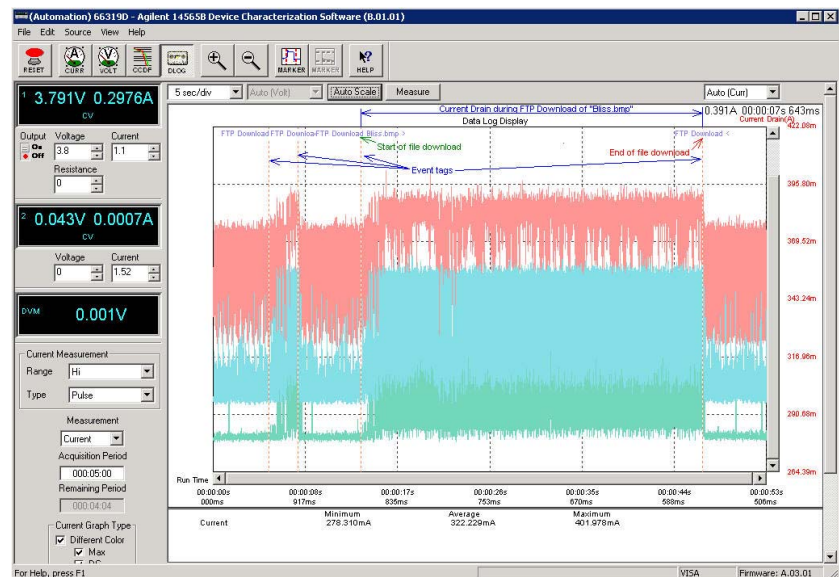

Figure 3: Current drain results using IFT to start an FTP download and control the 14565B software

Figure 4 also shows an example battery current drain profile, although this time the acquisition mode was CCDF, which provides statistical measurements for profiling signal levels.

Summary

With the 8960/IFT solution, battery drain analysis can be easily performed in combination with various activities that are supported by your device as a natural component of DUT testing. Not only does this solution make real world battery drain analysis possible, it also allows for both interactive and automated device testing.

These methods provide an easy way for you to more thoroughly test your phone in ways that are not practical by manual means.

Whether you are a design engineer looking for ways to optimize the run-time of your device, perform high level integration tests, or do more rigorous stress testing on your device to validate it before it gets released to the field, this 8960/IFT solution will find battery drain issues earlier. Finding and resolving issues earlier reduces time-to-market and, at the same time, allows you to bring higher quality products to market.

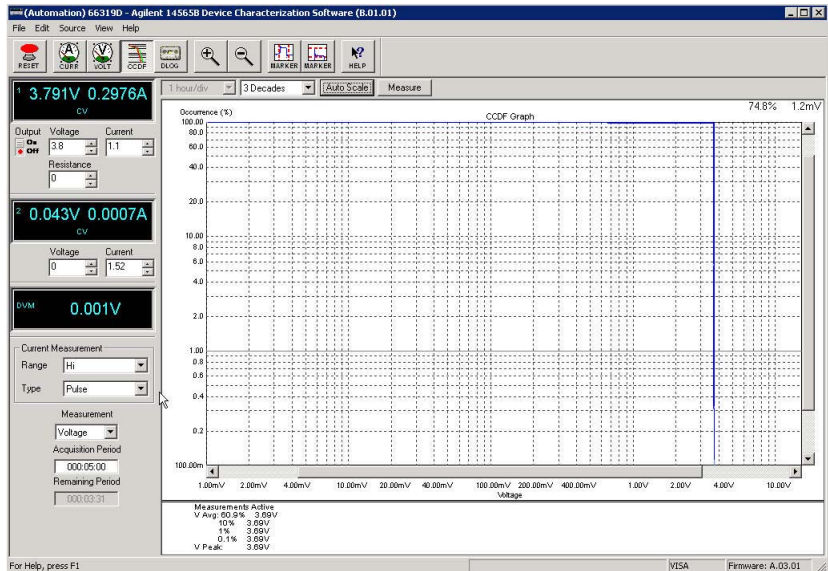

Figure 4: Example of CCDF result while performing an FTM download



Agilent Email Updates

www.agilent.com/find/emailupdates
Get the latest information on the products and applications you select.



Agilent Direct

www.agilent.com/find/agilentdirect
Quickly choose and use your test equipment solutions with confidence.



Agilent Open

Agilent open simplifies the process of connecting and programming **test systems** to help engineers design, validate and manufacture electronic products. Agilent offers open connectivity for a broad range of system-ready instruments, open industry software, PC-standard I/O and global support, which are combined to more easily integrate test system development.

Remove all doubt

Our repair and calibration services will get your equipment back to you, performing like new, when promised. You will get full value out of your Agilent equipment throughout its lifetime. Your equipment will be serviced by Agilent trained technicians using the latest factory calibration procedures, automated diagnostics and genuine parts. You will always have the utmost confidence in your measurements.

Agilent offers a wide range of additional expert test and measurement services for your equipment, including initial start-up assistance, onsite education and training, as well as design, system integration, and project management.

For more information on repair and calibration services, go to:

www.agilent.com/find/removealldoubt

www.agilent.com

For more information on Agilent Technologies' products, applications or services, please contact your local Agilent office. The complete list is available at: www.agilent.com/find/contactus

Americas

Canada	(877) 894-4414
Latin America	305 269 7500
United States	(800) 829-4444

Asia Pacific

Australia	1 800 629 485
China	800 810 0189
Hong Kong	800 938 693
India	1 800 112 929
Japan	0120 (421) 345
Korea	080 769 0800
Malaysia	1 800 888 848
Singapore	1 800 375 8100
Taiwan	0800 047 866
Thailand	1 800 226 008

Europe & Middle East

Austria	0820 87 44 11
Belgium	32 (0) 2 404 93 40
Denmark	45 70 13 15 15
Finland	358 (0) 10 855 2100
France	0825 010 700*
Germany	01805 24 6333**
Ireland	1890 924 204
Israel	972-3-9288-504/544
Italy	39 02 92 60 8484
Netherlands	31 (0) 20 547 2111
Spain	34 (91) 631 3300
Sweden	0200-88 22 55
Switzerland	0800 80 53 53
United Kingdom	44 (0) 118 9276201

Other European Countries:

www.agilent.com/find/contactus

Revised: March 27, 2008

Product specification and descriptions in this document subject to change without notice.

© Agilent Technologies, Inc. 2008
Printed in USA, July 2, 2008
5989-9153EN

